

Montageanleitung

Mounting instruction

für Hochschwenkbeschlag im Oberschrank mit Alu-Profil
und 2 Gasdruckfedern

for swing-up fitting with Alu-Profile in the wall unit and 2 gas springs

Art.-Nr.222866, Art.-Nr.222868, Art.-Nr.222867

1. Hochschwenkbeschlag
Swing-up fitting

2. Gasfeder
gas spring

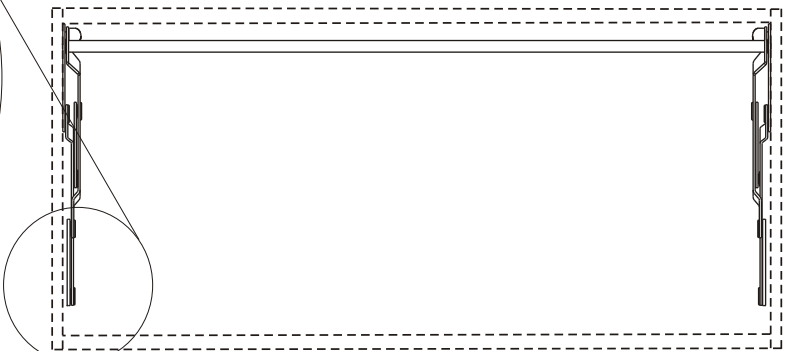
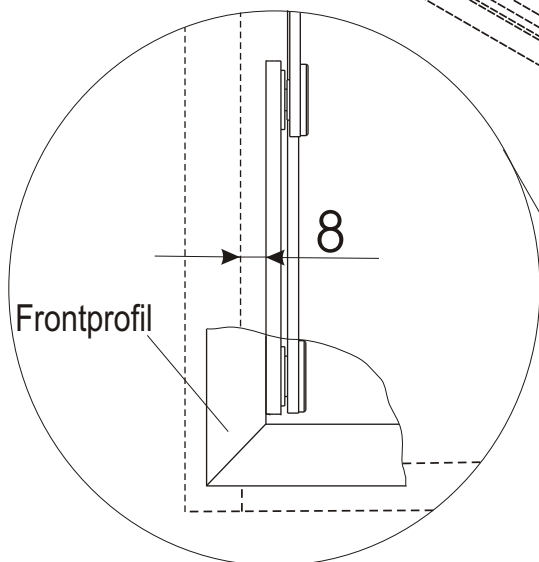
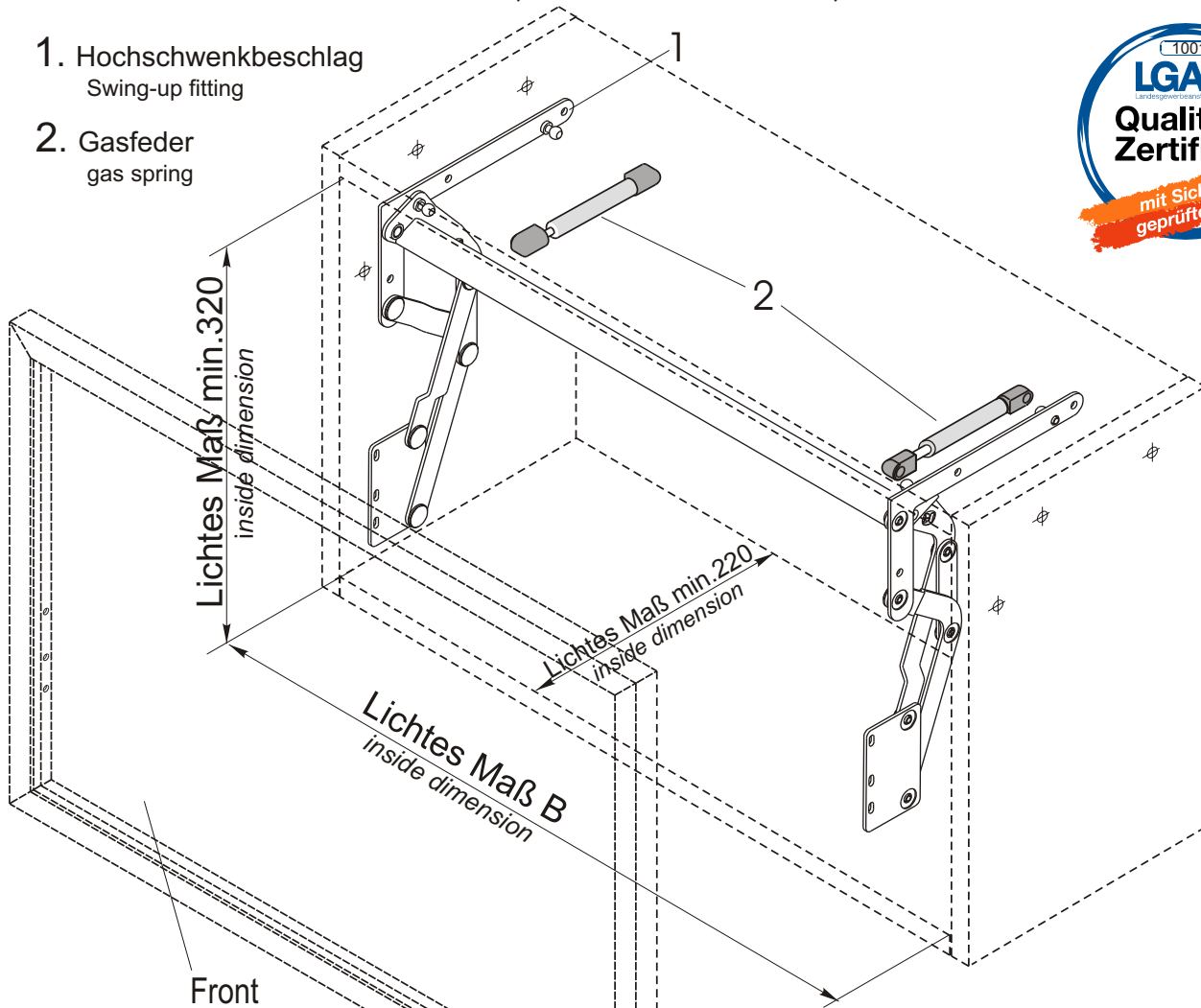

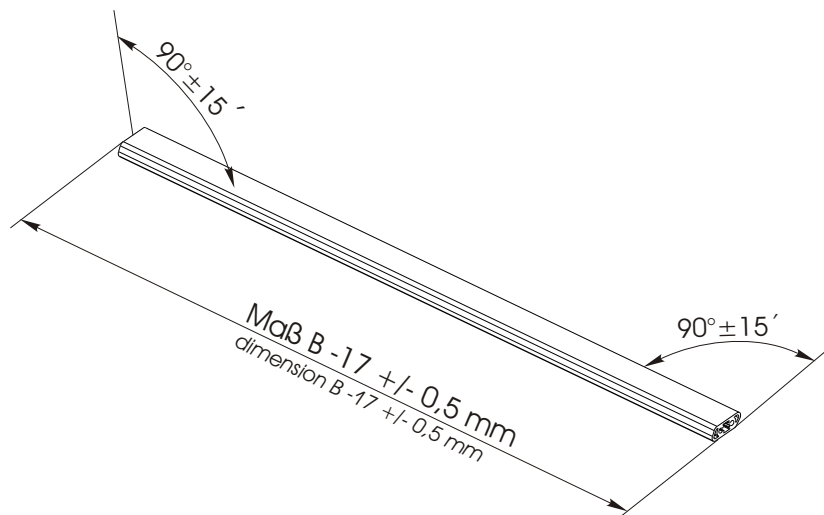

Art.Nr.Kesseböhmer:	Maß "B" dimension "B"	maximales Frontgewicht max. frontweight
222866	max. 870 mm	5,0 kg
222868	max. 1170 mm	7,0 kg
222867	max. 1470 mm	8,5 kg

A. Profil zuschneiden Cut up the profile

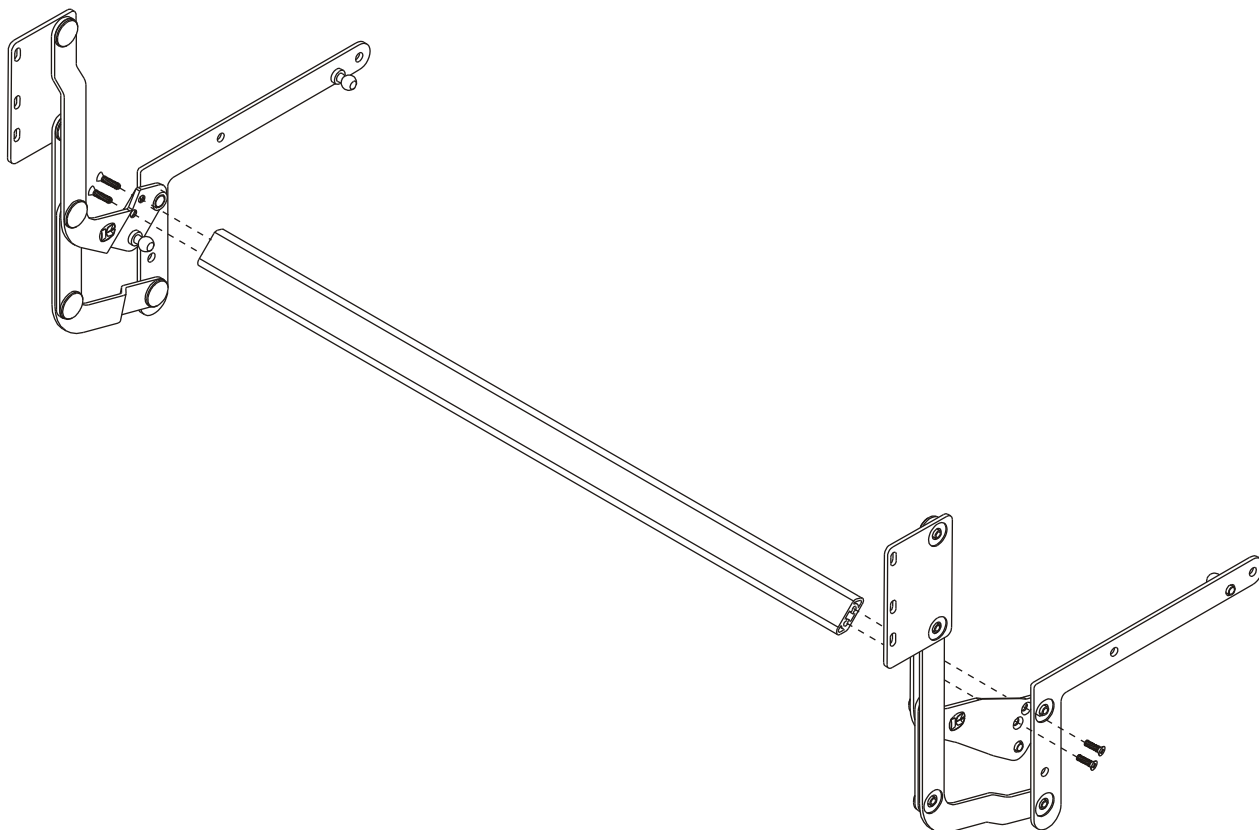

B. Hochschwenkbeschlag montieren Mount the swing-up fitting



Blechschaube
DIN 7982

4,2x16-c 4x

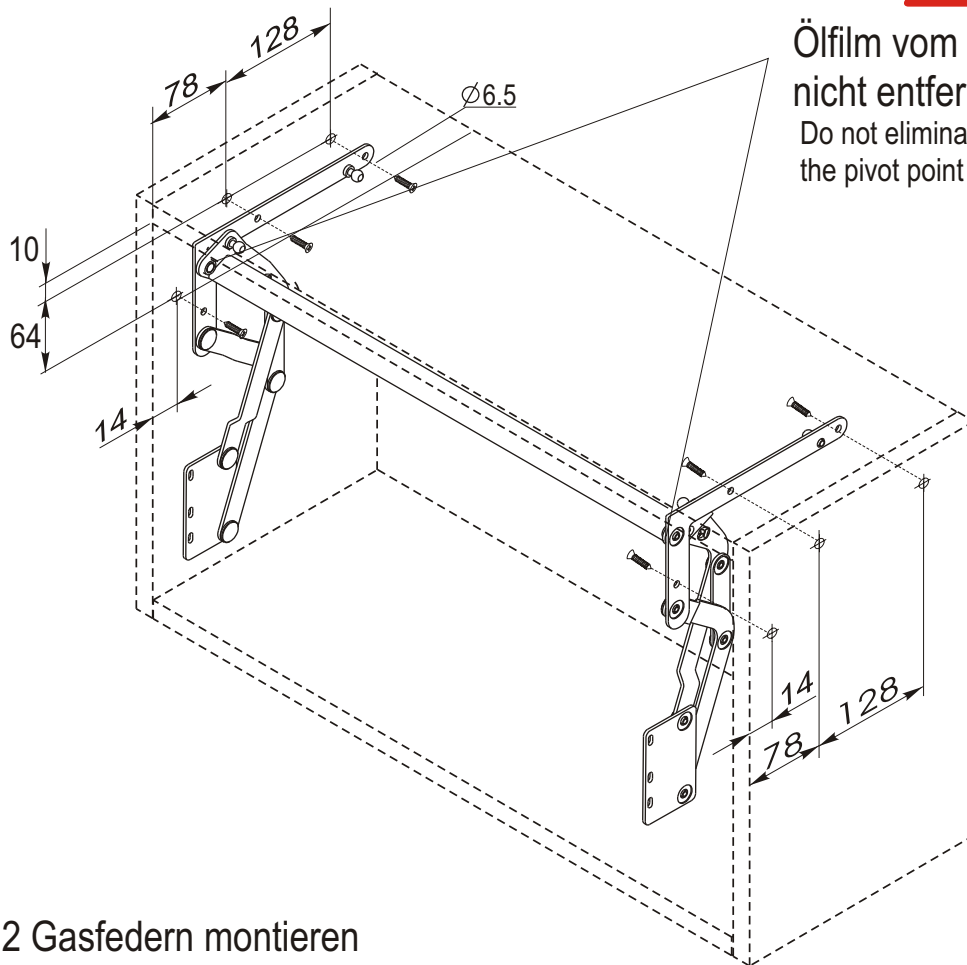
C. Hochschwenkbeschlag einschrauben Screw the swing-up fitting

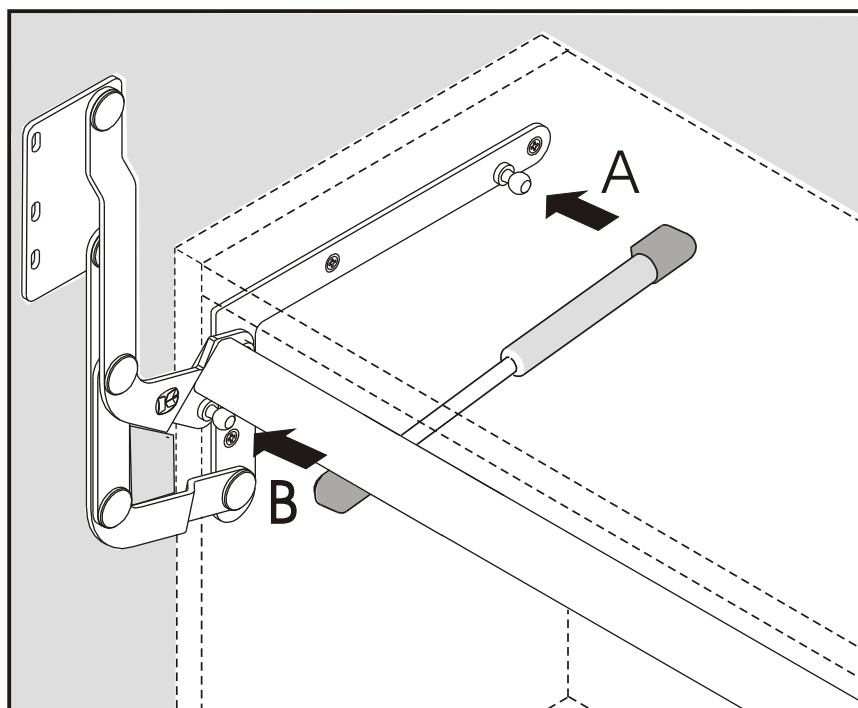

D. 2 Gasfedern montieren mount the gas springs



E. Front

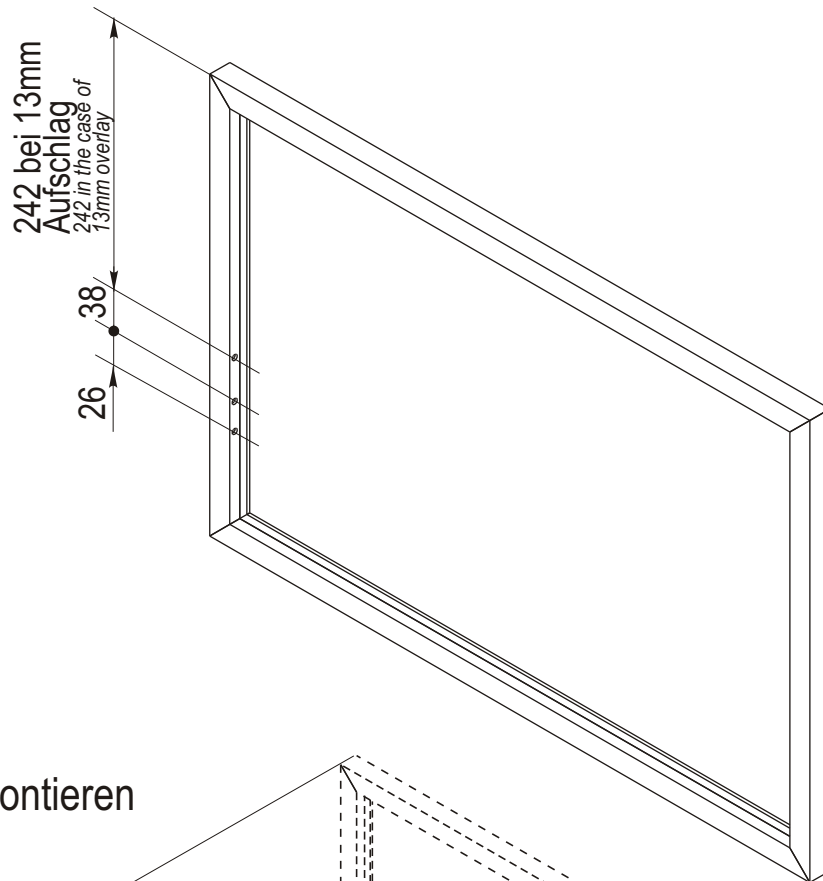

F. Front montieren

