

Pressomat 100 / 200 and retrofitting set (optional)

applies to Cat. No.:
 553.69.003
 553.69.004
 553.69.007



Installation and operating instructions also available as video!
 Further information is available at:
www.hafele.de/moovit

1. General information	2
2. Technical description	2
3. Appropriate application	2
4. Safety instructions	2
4.1 Safety instructions for the transport / installation	2
4.2 Safety instructions for installation.....	2
4.3 Safety instructions for the operation, maintenance	2
5. Transport	2
6. Unpacking / Check delivery	2
7. Installation	3
7.1 Installation conditions	3
7.2 Pressomat installation	3
7.3 Extension assembly	3
7.4 Retrofitting set assembly.....	4
8. Operation	5
8.1 Set the drawer width.	5
8.2 Set the drawer length.	5
8.3 Secure the bottom and rear panel.....	6
8.4 Insert drawer sides.....	6
8.5 Attach the drawer sides and rear panel. Pressomat 100:	7
8.6 Attach the drawer sides and rear panel. Pressomat 200:	7
9. Maintenance and repair	8
10. Spare parts	8
11. Technical data	8

1. General information

This guide is intended for woodworkers. Please read instructions completely before beginning operation. Please keep instructions with unit for future reference.

2. Technical description

Drawer components can be assembled in small batch production with the aid of the Pressomat.

- **Maximum drawer width:**
up to 600 mm (without extension)
up to 1200 mm (with extension (included))
- **Required bottom panel thickness:** 16 mm.
- **Adjustable drawer side lengths:** 270 - 300 - 350 - 400 - 450 - 500 - 550 - 600 - 650 mm.

Two models are described in this manual. They differ as follows:

- **Pressomat 100 (Cat. No.: 553.69.003):**
Drawer sides and bottoms are screwed together.
- **Pressomat 200 (Cat. No.: 553.69.004):**
Drawer sides and bottoms are interlocked.

Pressomat 100 can be converted into a Pressomat 200 by attaching a retrofitting set (optional; Cat. No.: 553.69.007).

3. Appropriate application

The Pressomat may only be used in the manner as described in this manual. Any other use is considered as unintended and is therefore not allowed.

4. Safety instructions

4.1 Safety instructions for the transport / installation



Risk of injuries from falling loads!

- > Use suitable lifting equipment for transporting with a pallet, such as a forklift.
- > Observe total weight (see "11. Technical Data").
- > Call a second person to help when lifting from the pallet and setting up the Pressomat.

4.2 Safety instructions for installation



Risk of crushing injuries during the installation of the extension!

- > Secure the Pressomat with wooden blocks against falling prior to removing the lateral metal plate.

4.3 Safety instructions for the operation, maintenance



Risk of crushing injuries when operating with one hand!

- > Only operate the levers simultaneously using both hands.

5. Transport



Risk of injuries from falling loads!

- > Use suitable lifting equipment for transporting with a pallet, such as a forklift.
- > Observe total weight
- > (see "11. Technical Data").
- > Call a second person to help when lifting from the pallet and setting up the Pressomat.

6. Unpacking / Check delivery

- [1] Remove straps.
- [2] Dispose of packaging material environmentally friendly.
- [3] Check the delivery for completeness and inspect for shipping damage.
- [4] Contact the manufacturer, if parts are missing or damaged.

7. Installation

7.1 Installation conditions

Space requirements, table dimensions:

- without extension: **Min. table length of 120 cm**
- with extension: **Min. table length of 180 cm**
- **Min. table width of 75 cm**
- **Clearance** (in addition to table height):
Pressomat 100 min. 90 cm;
Pressomat 200 min. 110 cm
- **Recommended table height:** 350 - 400 mm

Minimum load bearing capacity of the table

- Pressomat 100: 200 kg
- Pressomat 200: 250 kg

Installation tools

- Philips screwdriver
- 6 mm Hex key

7.2 Pressomat installation

[1] Place the Pressomat on the table.

[1] Screw in four screws (not included).

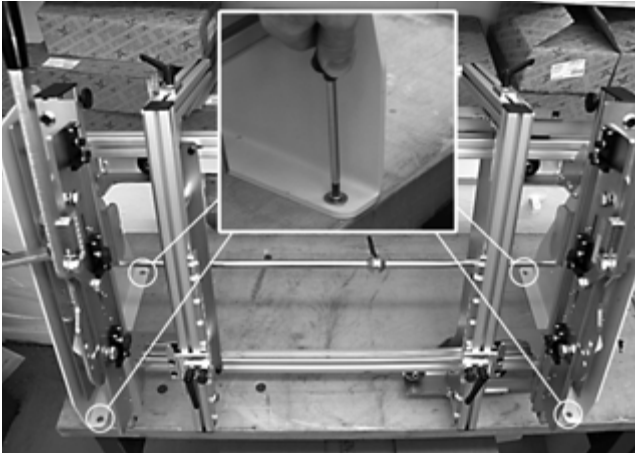

7.3 Extension assembly

⚠ Risk of crushing injuries during the assembly of the extension!

- > Secure the Pressomat with wooden blocks against falling prior to removing the lateral metal plate.

Note:

The Pressomat can only be extended to the right..

[1] Place wooden blocks underneath.



[2] Unscrew three screws.
Remove the right metal plate.

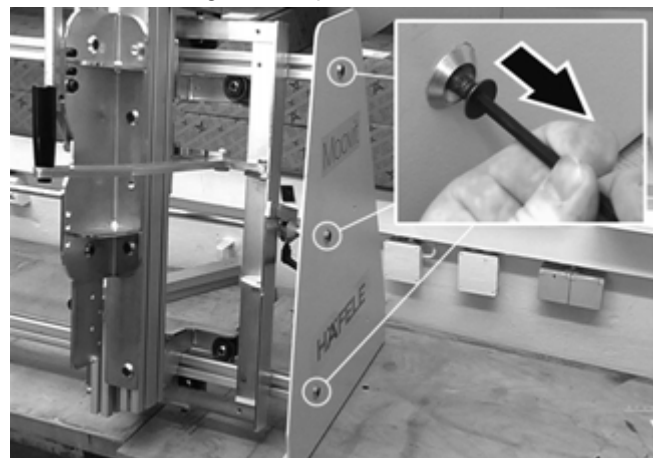

[3] Attach extension sections.

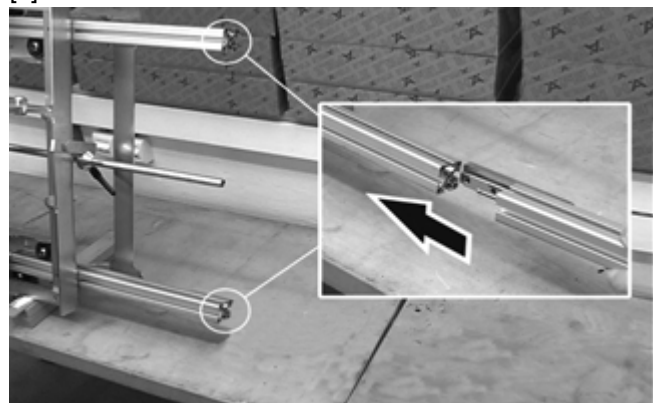

7.4 Retrofitting set assembly

[4] Attach the extension sections with 2 screws.

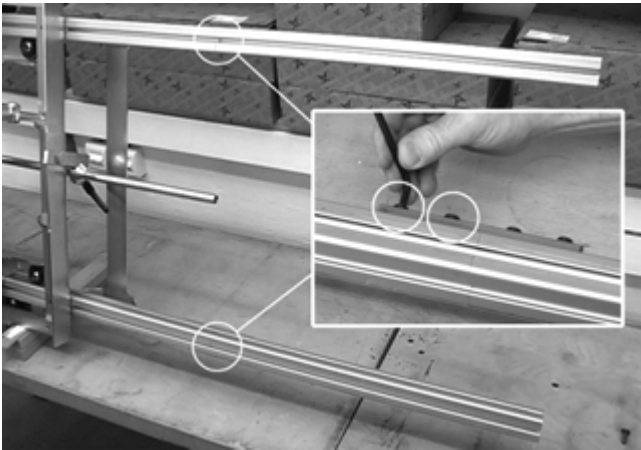

[5] Manually screw in the extension rod. Insert the right metal plate.

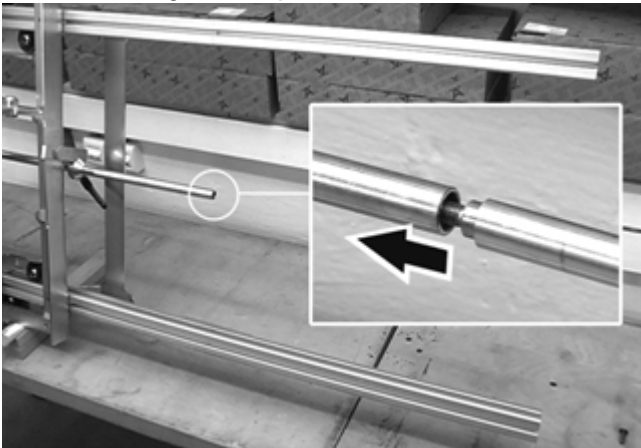

[6] Screw in three screws and tighten.

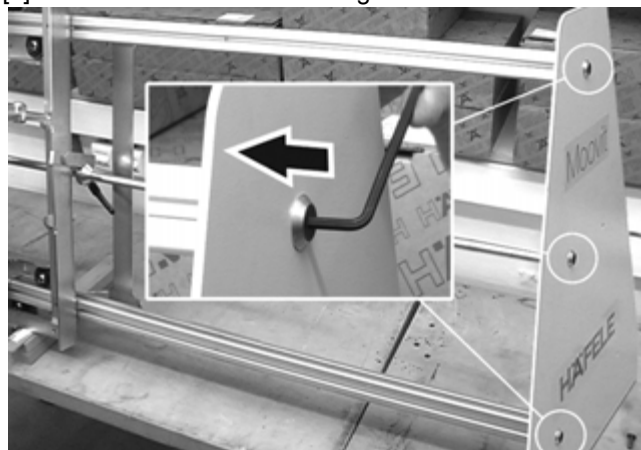

[1] Unpack the retrofitting set and keep available.

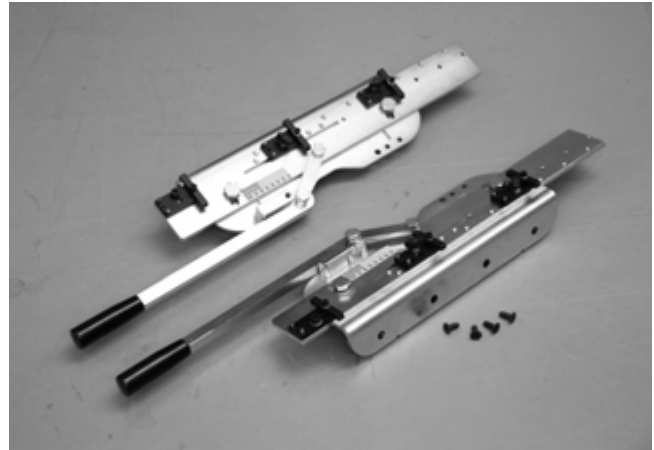

[2] Unscrew four screws and set aside.

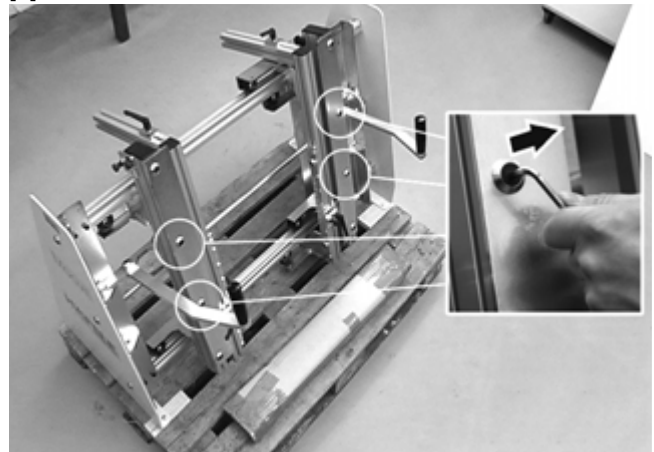

[3] Attach both clamping arms with two included screws (length of 30 mm). Observe the position (see image).

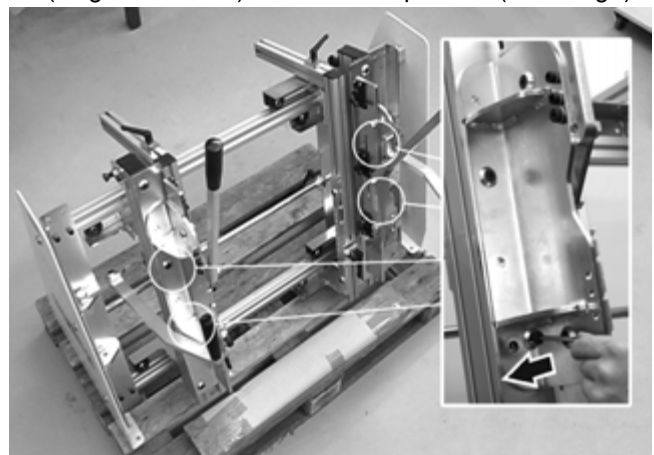

8. Operation

8.1 Set the drawer width.

[1] Place the drawer bottom on the left clamping arm.

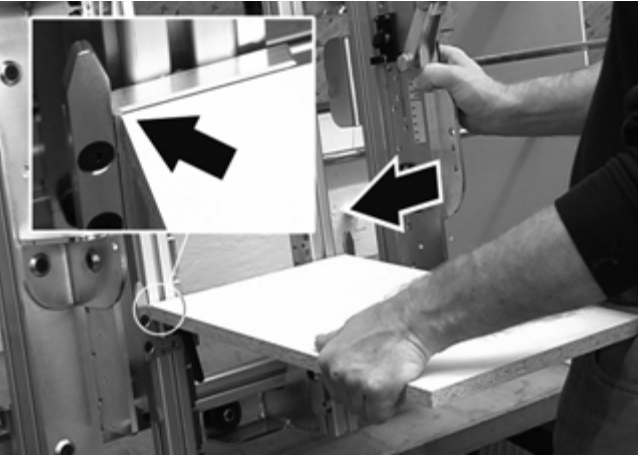

[2] Push the right clamping arm to the stop.

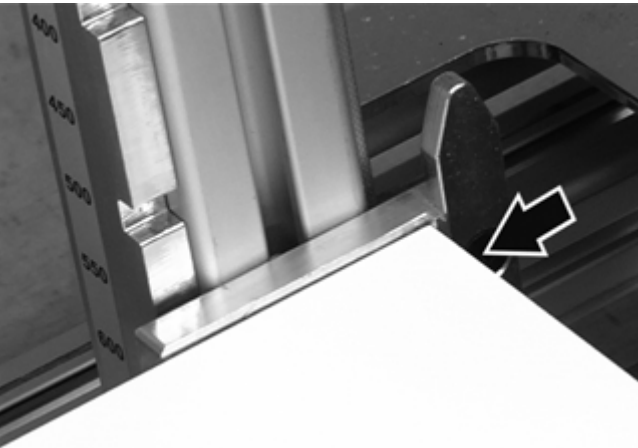

[3] Fix the position with the positioning device.



8.2 Set the drawer length.

[1] Slide the blocks to the required position by releasing the levers.

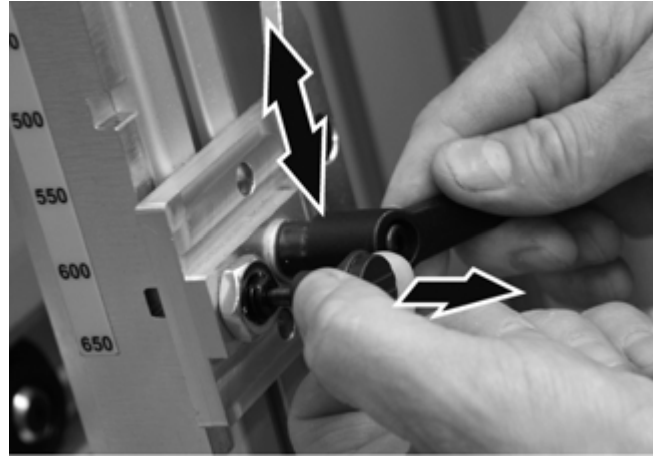

Note:

Each notch is assigned to a certain drawer side length. The following drawer side lengths can be adjusted: 270 - 300 - 350 - 400 - 450 - 500 - 550 - 600 - 650.



[2] Snap bracket into the desired notch. Secure the position by tightening the lever.



8.3 Secure the bottom and rear panel

[1] Insert the bottom panel.

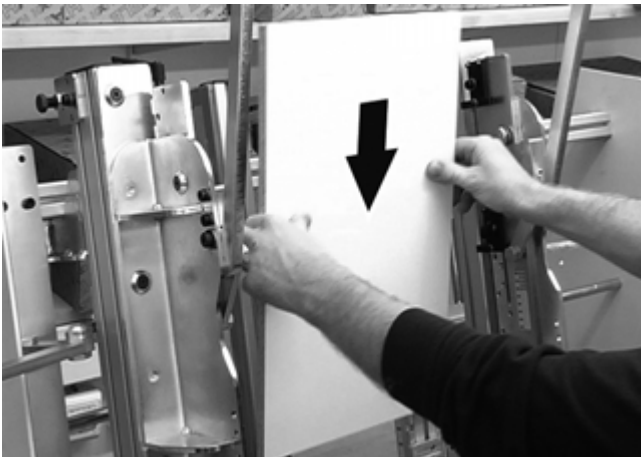

[2] Push the back panel flush to the bottom.



[3] Clamp the rear panel with depth gauges.
Tighten the lever.

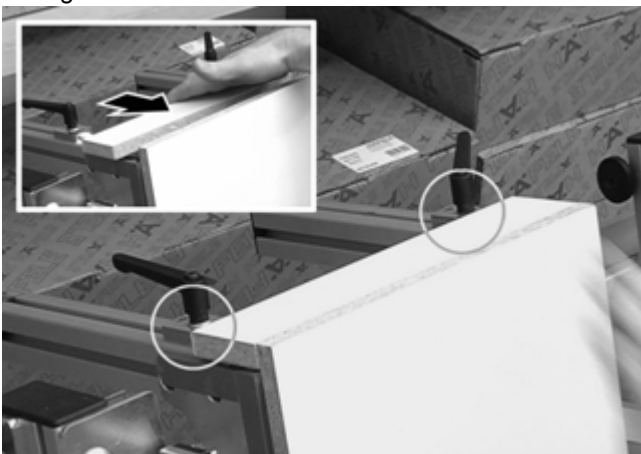

8.4 Insert drawer sides

[1] Push the drawer side from above between the bottom panel and the drawer side pin and press against the bottom. Repeat the process with the second drawer side.



⚠ Risk of crushing injuries when operating with one hand!

> Only operate the levers simultaneously using both hands.

[2] Press together both clamping levers.

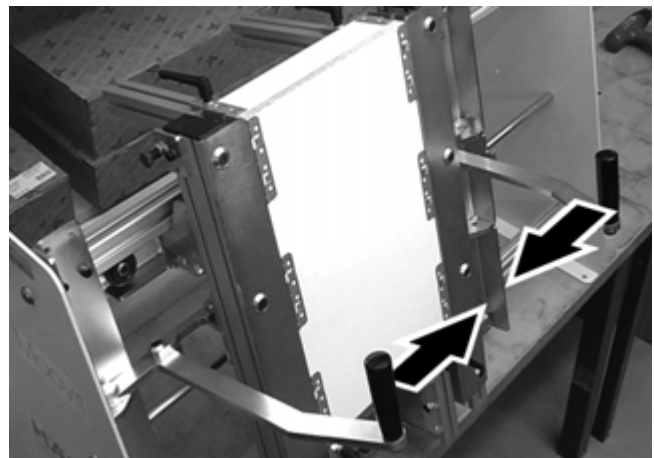

8.5 Attach the drawer sides and rear panel. Pressomat 100:

[1] Fix screws 3.5 x 15 mm (#6 x 5/8"-Flathead) into bottom panel (quantity as required).

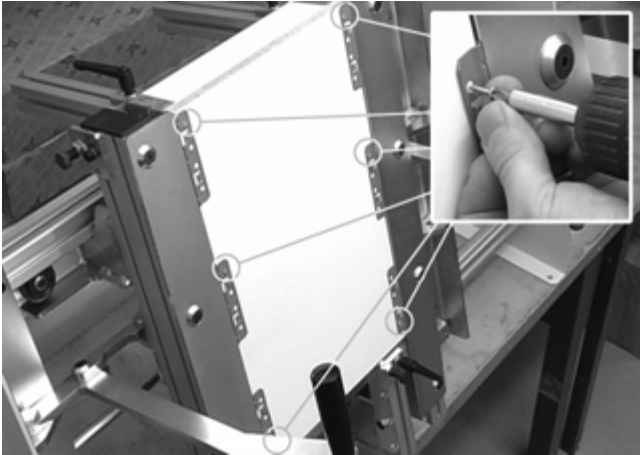

[2] Fix screws 3.5 x 15 mm (#6 x 5/8"-Flathead) into rear panel (quantity as required).

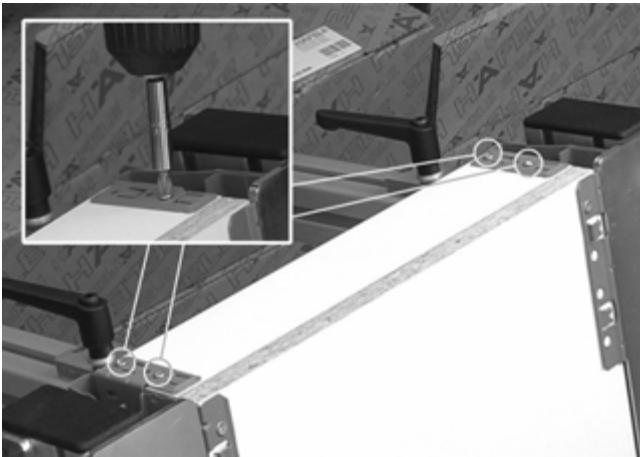

[3] Open both clamping levers. Remove the drawer.

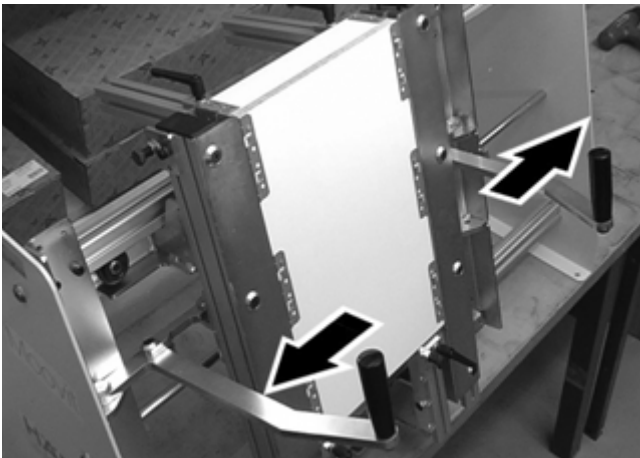

8.6 Attach the drawer sides and rear panel. Pressomat 200:

[1] If necessary, align the lower press in unit holder to the lower claws of the drawer sides. Remove the wing bolt and move the press in unit holder.

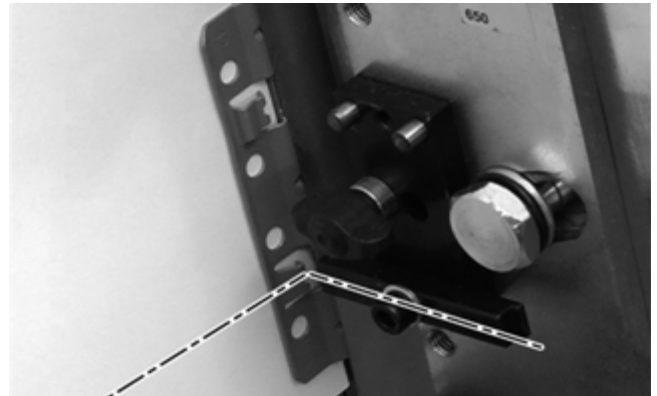

⚠ Risk of crushing injuries when operating with one hand!

> Only operate the levers simultaneously using both hands.

[2] Press both pressing levers up to the stop. The claws are thereby pressed into the bottom panel. Drawer sides and bottom panel are connected.

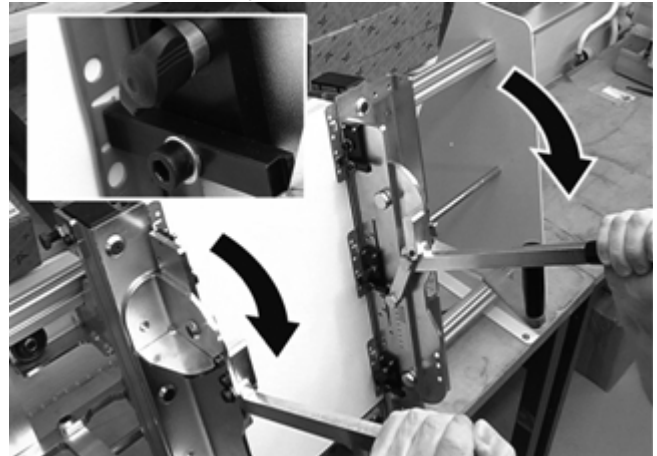

[3] Fix screws 3.5 x 15 mm (#6 x 5/8"-Flathead) into rear panel (quantity as required).

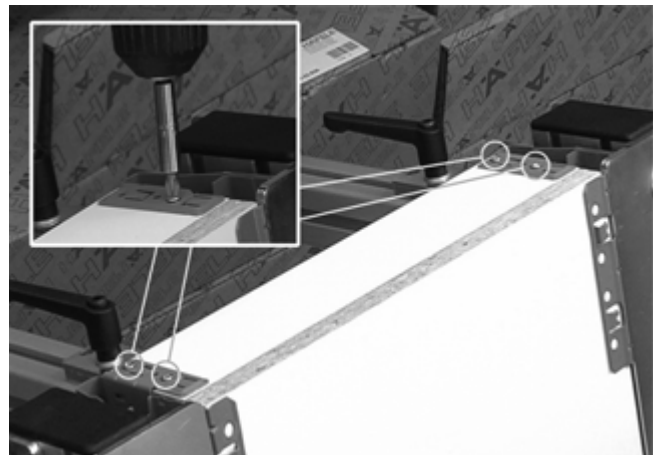

[4] Open all levers and remove the drawer.



9. Maintenance and repair

- Lubricate all movable parts as necessary.

10. Spare parts

- Replace damaged parts.
- Only use original replacement parts.
- For replacement parts please contact your local Häfele sales office.

11. Technical data

Dimensions of the Pressomat 100:

- Length (without extension): 116 cm
- Length (with extension): 177 cm
- Width: 71 cm
- Height: 81 cm
- Weight: 82.5 kg (182 lbs)

Dimensions of the Pressomat 200:

- Length (without extension): 116 cm
- Length (with extension): 177 cm
- Width: 71 cm
- Height: 100 cm
- Weight: 100 kg (220 lbs)

Pressomat retrofitting set

- Weight: 17.5 kg (39 lbs)